

A close-up photograph of a cardboard box on a conveyor belt. The conveyor belt features a grey metal deck with a grid of circular perforations, through which blue rollers are visible. The box is positioned on the left side of the frame, moving towards the right. The background is a plain, light-colored wall.

faigle

faigle components

for intralogistics systems

moving forward

faigle components for
intralogistics systems –
tried and trusted millions
of times over



Watch our video:
The Life of a Parcel

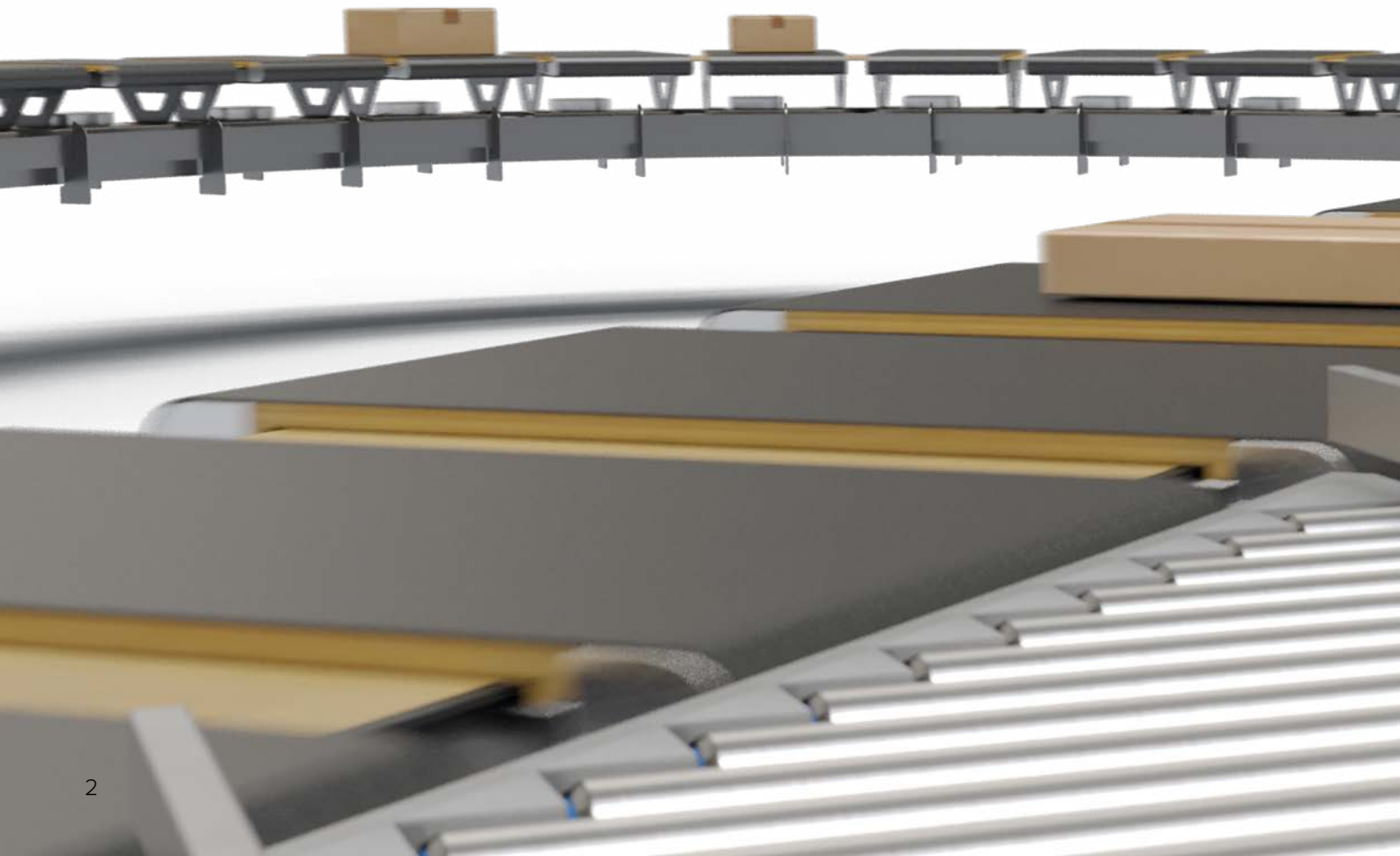

At faigle, we began developing the first wheels made of thermoplastic polyurethane in 1968. And we've been refining our plastic wheels ever since.

Every year, the company delivers millions of wheels for warehouse logistics, sortation and conveying systems to major manufacturers like Vanderlande, Beumer, TGW and many more besides.

faigle wheels are the number-one choice around the world whenever demanding applications require a long service life. They are individually designed for continuous operation under tough conditions, in applications ranging from underground station escalators to high-speed parcel sortation and baggage handling systems.

faigle is the international market leader, and its outstanding reputation comes courtesy of a range of products built specifically for intralogistics systems, coupled with their excellent value for money.



Applications for faigle intralogistics components

Sortation systems

Products

- Support and guiding wheels page 06
- SE sorter running wheels page 08
- Swivel wheel comfort page 12



Conveying systems

- Diverter wheels page 10
- Belt deflection wheels page 14
- Bearing shield and housing page 16
- Wheel clips page 18



Warehouse logistics systems

Products

- Shuttle wheels page 20
- Shuttle flaps page 22
- Overhead conveyor carriages page 24



AGV systems

Products

- AGV wheels page 26

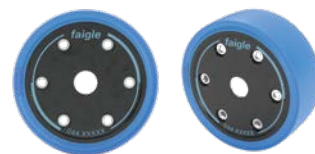



Support and guiding wheels

Application / Challenges

In the intralogistics sector, support and guiding wheels are mainly used in sortation and conveyor systems.

They have to withstand very high loads due to the extremely tough operating conditions. High availability is vital for sortation systems – breakdowns and maintenance stoppages usually bring long logistics chains to a standstill.

Support and guiding wheels need to operate reliably for years on end, often around the clock, without the need for maintenance. Other key requirements include low noise emissions and minimal running resistance.

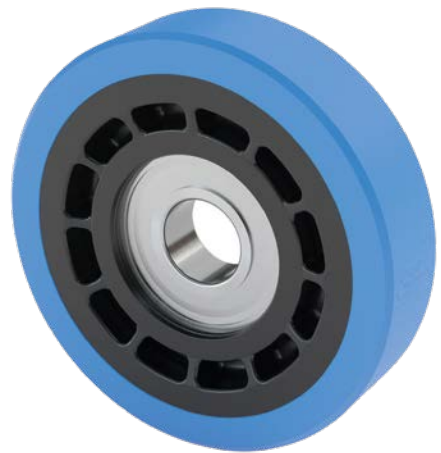



Solution / Material

The tyres on our support and guiding wheels are made from PAS-PU, a thermoplastic elastomer with excellent tear resistance and outstanding mechanical properties. It is also fully hydrolysis-resistant.

On the 1C wheels, the highly pre-tensioned tyre is attached directly to the ball bearing. The tyre on the 2C wheel is non-detachable and welded directly onto the fibre-glass-reinforced polyamide hub. The ball bearing on this model is fully enclosed by the hub.

faigle only uses ball bearings from selected manufacturers audited by the company.

Customer benefits

- ✓ Long service life thanks to hard-wearing material – significantly higher abrasion resistance compared with rubber
- ✓ No hydrolysis-related ageing or damage – reliable operation, including in damp environments
- ✓ Shorter lead times and cost-effective production thanks to injection moulding
- ✓ Securely fitted tyre ensures reliable operation
- ✓ 2C wheel also suitable for axial loads, misalignment and cornering
- ✓ Quality-approved ball bearings that meet the highest standards ensure trouble-free operation over many years

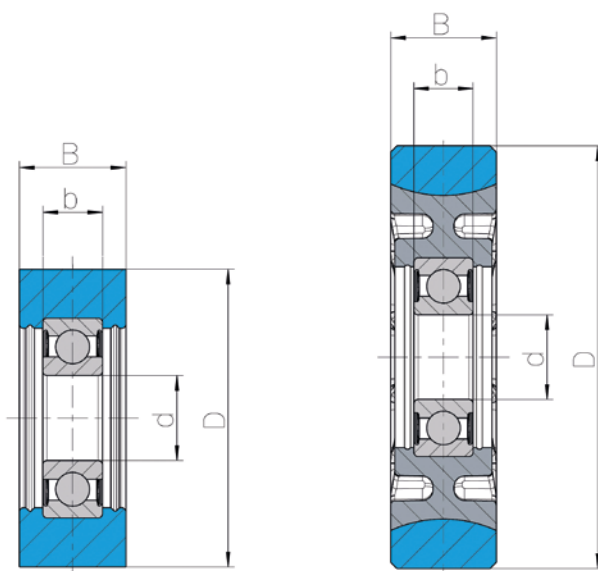

Rolle 1 K

Rolle 2 K

Specifications

D	30 – 120mm
d	6 – 20mm
B	12 – 35mm
b	6 – 16mm

Tyre hardness:	75 – 95 Shore A 54 – 65 Shore D
Load capacity:	100 – 2.000 N
Speed:	0 – 4m/s

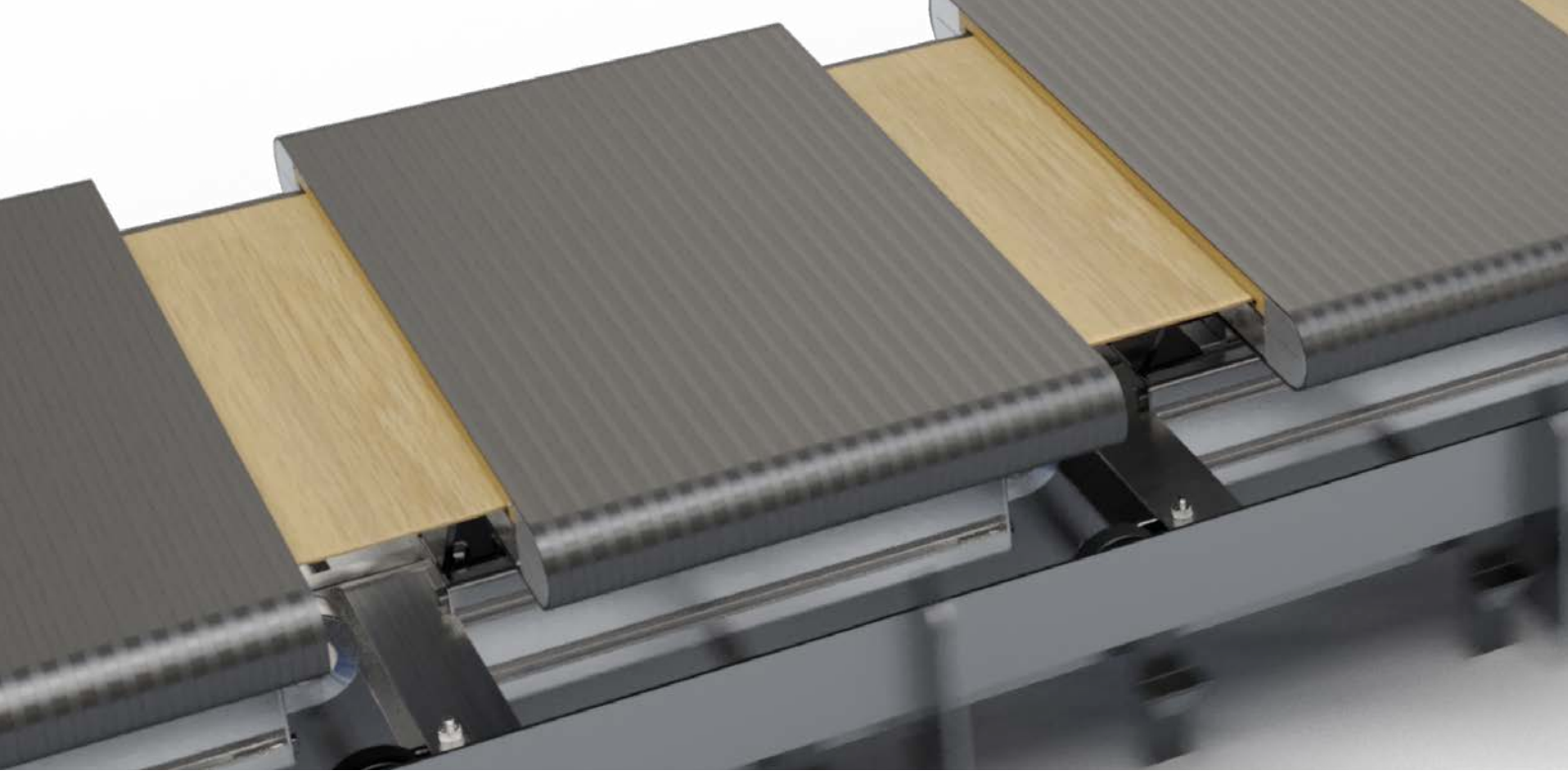

SE sorter running wheels

Application / Challenges

Alongside comprehensive operational reliability and quiet, vibration-free running, energy consumption is increasingly becoming a key consideration for sortation system operators.

Running wheels for these systems need to operate reliably for years on end, without the need for maintenance. Particularly low running resistance is also essential in order to minimise the systems energy consumption.

In turn, low start-up torque is vital for the layout of the drive stations in the system.

Meanwhile, good damping properties and low noise emissions help to improve working conditions for operating staff.



Solution / Material

High performance, low consumption: faigle's next-generation wheels can cut the energy consumption of parcel sortation and baggage handling systems up to 20 - 30%. The wheels run smoothly and quietly thanks to their optimised concentricity and running resistance. A unique damping system absorbs shocks and vibrations.



faigle's new running wheels feature a polyamide hub with a PAS-PU TCS tire. The specially developed running surface stands out for its minimal compression set. This all but eliminates flattening even after long stoppages, which in turn saves energy when the system restarts. The higher-strength wheel construction allows for a narrower tire without compromising on load-bearing capacity or running smoothness – this translates into lower running resistance, cutting energy demand in day-to-day operations.

The SE running wheel has outstanding damping properties, thanks to the unique faigle damping system (FDS). It provides highly effective protection against shocks and vibrations from the wheel suspension, with no adverse effects in terms of rolling resistance. The wheel's ribless design is also completely new. It helps to ensure low-vibration concentricity, while the smooth outer contour reduces dust deposits, for effective protection against pockets of dirt.

The completely black SE running wheel is available with laser marking in light grey.

Customer benefits

- ✓ Optimum energy efficiency thanks up to 20 - 30% reduction in start-up and running resistance
- ✓ Integrated faigle Damping System (FDS) reduces operating noise
- ✓ No hydrolysis-related ageing or damage – reliable operation, including in damp environments
- ✓ Strong tire bonding maximises reliability
- ✓ Quality-approved ball bearings that meet the highest standards ensure trouble-free operation over many years

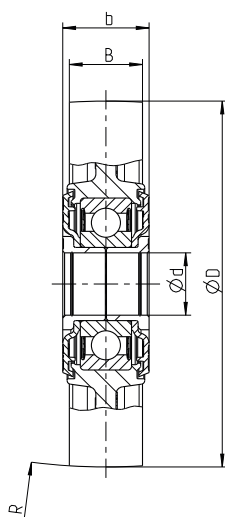

Specifications

D 70 – 120mm
 d 10 – 30mm
 B 15 – 35mm
 b 16 – 35mm

Tyre hardness: 85 – 95 Shore A
 54 – 64 Shore D

Load capacity: 300 – 2.000 N

Speed: 0 – 5m/s



Diverter wheels

Application / Challenges

Diverter wheels are powered conveyor elements that change the direction in which goods flow in a conveying system.

The combination of relatively high speeds, the weight of the moving goods and diversion angles of up to 90° mean that the wheels are exposed to huge forces. What's more, significant reciprocal abrasion is produced when the drive belt and the wheel come into contact.





Solution / Material

faigle diverter wheels feature a multi-component construction, comprising a polyamide hub and two thermoplastic polyurethane (TPU) tyres, with a metal ring serving as the liner.

We use a very stiff hub made from carbon-fibre-reinforced polyamide to enhance the wheel's load-bearing capacity. Elastic but also robust, TPU tyres provide optimum grip and high abrasion resistance. The tyres are securely welded onto the hub and remain firmly in place despite the strong axial forces exerted on the wheel. The metal insert provides an ideal mating surface for the round belt, so it protects both the wheel and the belt against wear.

All of the materials used can be supplied with electroconductive properties, which means any electrostatic build-up is discharged.

Customer benefits

- ✓ Secure welding between running surface and hub improves operating reliability
- ✓ Optimum coefficient of friction delivers reliable diversion
- ✓ Outstanding abrasion resistance extends service life
- ✓ Electroconductive materials eradicate electrostatic build-up
- ✓ Extremely cost-effective thanks to efficient production using injection moulding
- ✓ Lower installation costs thanks to delivery of assemblies including shaft and circlips

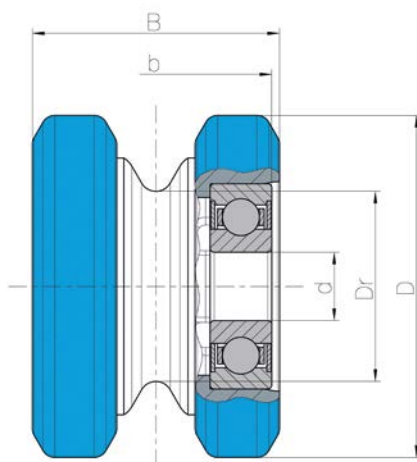

Specifications

D	35 – 70 mm
Dr	20 – 50mm
B	35 – 70mm
d	6 – 25mm
b	20 – 70mm

Tyre hardness:	75 – 95 Shore A
Load capacity:	100 – 500 N
Speed:	1.5 – 2.5 m/s



Swivel wheel comfort

Application / Challenges

Wheel holders are part of the carriers that are used in parcel sortation and baggage handling systems. Due to the kinematic effects generated during cornering, the running wheels on the carriers need to be fitted in such a way that they can swivel. Conventional wheel holders are usually made from steel or aluminium. They have to bear the weight of the carrier and the load, while also withstanding shocks and centrifugal forces when taking corners. Even when the wheel holders are carrying significant loads, deformation has to be kept to an absolute minimum to stop the carrier from sinking. The pivot bearing needs to be play-free and silent, and to work reliably during their long service life.

Another key requirement is acoustic decoupling of the wheel and the carrier, in order to minimise the transfer of vibrations and noise.

Solution / Material

The wheel holder for the Swivel wheel comfort comprises just four parts – three of which are standard components.

The weight of the holder is only a fraction of that of comparable steel and aluminium solutions, which helps to cut the sortation system's drive energy requirements.

Thanks to its high-strength design featuring highly rigid, impact-resistant, carbon-fibre-reinforced polyamide, the wheel fork is ideally suited to handling heavy loads. The fork's design is based on a platform that can be scaled according to the customer's specific geometric requirements.



The plastic wheel shaft is so stable that it significantly exceeds the load-bearing capacity of the ball bearing. Fitted in damping bushings, the wheel shaft is securely attached by inserting it into the fork from the underside. This can be done by hand, with no tools required.

The damping bushings ensure low-noise, low-vibration operation and, because they do not rotate, they do not cause additional running resistance.

The material used for the wheel fork has the specific task of bearing the wheel fork for the swivel motion. With this function in mind, the material has optimised tribological properties and does not require any lubrication during the service life of the wheel holder.

The wheel holder has an antistatic design as standard. Ready to install, the faigle Swivel wheel comfort model is supplied with a fully assembled running wheel.



Customer Benefits

- ✓ Lightweight design helps to cut drive energy requirements
- ✓ Cost-effective production and short lead times thanks to injection moulding technology
- ✓ Highly effective vibration damping reduces operating noise
- ✓ Low running resistance with similar noise level in combination with faigle's SE wheel
- ✓ Ready-to-install module reduces assembly time
- ✓ Excellent load-bearing capacity and rigidity thanks to high-performance plastics and optimised design
- ✓ Quick-change system for rapid, tool-free wheel replacement
- ✓ Fast and efficient wheel fork design suited to virtually any installation set-up thanks to flexible design platform
- ✓ Use of standard faigle parts and master mould concept translates into low investment costs and short lead times for setting up volume production

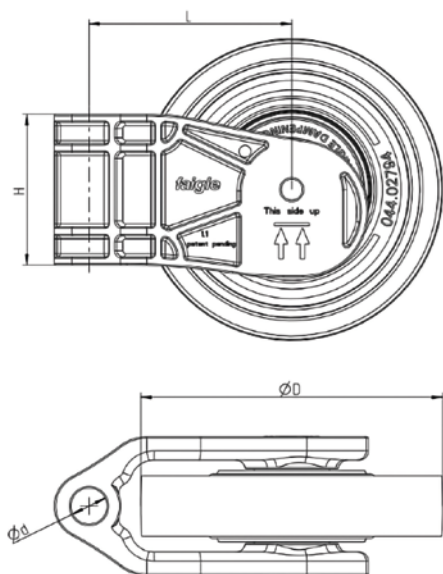

Specifications

Wheel diameter (D)	Ø 40 – Ø 120mm
Swivel axis – diameter (d)	~ Ø 8 – Ø 25mm
Centre distance (L)	~ 50 – 120mm
Height (H)	~ 20 – 80mm
Ball bearing	Standard 6204 Other bearings available on request



Belt deflection wheels

Application / Challenges

Belt deflection wheels are used in conveying systems, where they help to drive and deflect the drive belt, as well as maintaining tension and providing pressure and support.

High speeds and dynamic interaction between the belt and the wheel have a significant impact on both elements. If the surface of the wheel is smooth and abrasion-proof, this helps to extend the belt's service life.

Electroconductive wheels are crucial to prevent electrostatic build-up on the belt, which in turn protects any adjacent electronic components.





Solution / Material

faigle uses very stiff PAS-60GF ELS plastic for its belt deflection wheels. This long-lasting, wear-resistant material is also electroconductive, with a specific volume resistivity of $<10^4 \Omega\text{m}$.

A cost-effective alternative to turned parts, our injection moulding process produces a very smooth surface – here, the focus is on preventing burring and sharp edges resulting from misalignment of the mould.

Belt deflection wheels are custom-built in line with the requirements placed on them. Cylindrical and embossed designs are available, and other options include side flanges or custom surface structures such as longitudinal grooves. On request, we can supply belt deflection wheels as assemblies including holders or shafts.

Customer benefits

- ✓ Wear-free, gentle belt running thanks to extremely smooth, burr-free surface
- ✓ Electroconductive materials prevent electrostatic build-up
- ✓ Also available as finished assemblies including shafts and fastening system

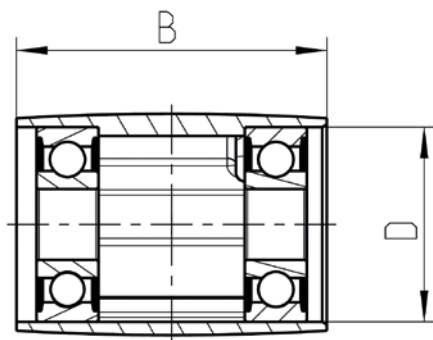

Specifications

- D 20 – 100mm
- B 30 – 80mm



Bearing shield and housing

Application / Challenges

Together with the ball bearing, the bearing shield and housing form a unit that maintains the conveyor wheel's position on the stationary shaft.

This unit is pressure-bonded with the conveyor wheel tube. The conveyor wheels can reach speeds of up to 2m/s, repeatedly braking and accelerating again. The bearing shield protects the ball bearing against external influences, preventing significant build-ups of dirt as well as mechanical damage. The shield is fitted on the inner ring of the ball bearing, joining it to the wheel shaft.

The housing is snapped on over the outer ring of the ball bearing and forms the connection with the wheel tube. Reliable protection against electrostatic build-up is vital for conveyor wheels.





Solution / Material

faigle has developed a solution that safely discharges electrostatic build-up directly through the plastic parts. There is no need for metal discharge elements such as brushes or copper thread. The bearing shield is available in a wide range of colours.

The volume resistance achieved is similar to that of electroconductive materials (10^4 – $10^7 \Omega\text{m}$). faigle's extensive experience shows that the conductivity of the plastic parts remains stable throughout their service lives.

The materials used score highly in terms of mechanical load-bearing capacity and impact strength.

Customer benefits

- ✔ Safe discharge of electrostatic build-up
- ✔ Retains conductive properties over many years
- ✔ Bearing shield available in large selection of colours
- ✔ Available for delivery as separate parts, or fully assembled including ball bearing

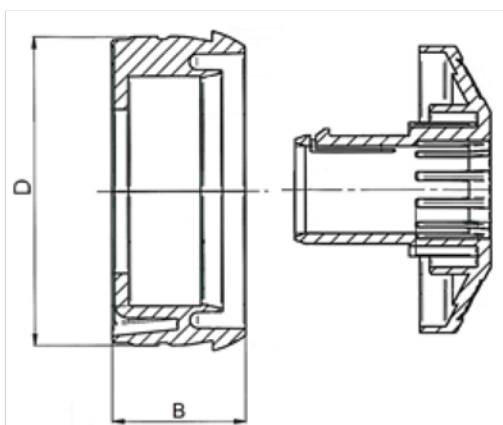

Specifications

D 40 – 80mm
B 15 – 50mm

Volume resistivity: 10^4 – $10^7 \Omega\text{m}$



Wheel clips

Application / Challenges

Wheel clips are used on roller conveyors, securing the conveyor wheels in the support profile.

It is vital that assembly and the replacement of the wheels can be carried out quickly, easily and – ideally – without tools. The bearings must be robust with zero play, and secured to ensure they cannot be dislodged. Safe discharge of electrostatic build-up from the wheel shaft to the support profile is a key function, while strong bonding in the connecting parts is just as important as the material's conductive properties.





Solution / Material

faigle wheel clips are single-part components with a locating hole for the wheel shaft, a groove for inserting it into the support profile, and a catch. They are adapted to the geometries of the wheel shafts and support profiles currently in use, in line with the customer's specifications.

The catch is designed so that the customer can easily feel and hear it click into place; it can also be released without using tools, and will not break even when it is closed and released repeatedly. The hole and the groove have microstructures which mean that the wheel clips rest on the wheel shaft and the support profile with a degree of pretension, which ensures good electrical bonding.

The wheel clips are made from an electroconductive polyamide that stands out for its high mechanical strength.

Customer benefits

- ✓ Easy, tool-free installation and removal
- ✓ Reliable, zero-play support for the conveyor wheels in the support profile
- ✓ Safe discharge of electrostatic build-up
- ✓ Repeated use possible thanks to wear-free function
- ✓ Custom-built to fit your wheel and profile geometry

Specifications

- T 8 – 20mm
- B 10 – 40mm
- H 20 – 60mm
- D 5 – 20mm

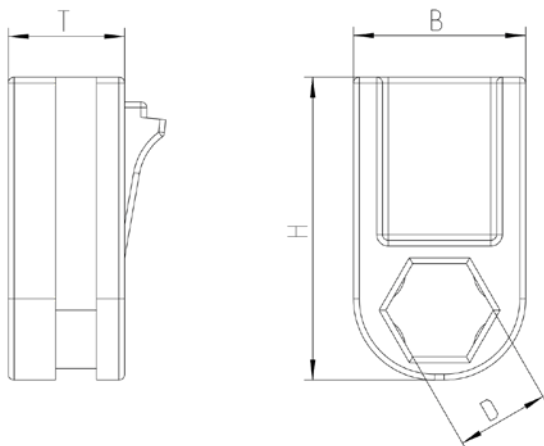



Shuttle wheels

Application / Challenges

Shuttle systems normally run on two or four driven wheels, resulting in high speeds and strong dynamic forces. Rapid shuttle braking and acceleration put significant stress on the tyres, so the wheels need to be firmly connected with the shuttle's drive shaft to ensure effective drive-torque transfer.

Vibrations in high-bay systems can also pose problems. This is the result of poor concentricity in the wheels, impacts from uneven rails or deposits on the rails. Vibrations cause goods to shift in the bays, so they cannot be gripped by the shuttle.

Smooth, vibration-free running at high speeds and excellent damping properties are essential for shuttle wheels.





Solution / Material

faigle shuttle wheels use a 2-component design with a polyamide hub and PAS-PU TCS tyre. A very stiff hub ensures a high load-bearing capacity. The wheel can be connected with the drive shaft by overmoulding an integrated metal part.

The specially developed running surface combines extremely high abrasion resistance with a low compression set. This all but eliminates flattening even after long stoppages, but the material is still soft enough to provide optimum grip and outstanding damping characteristics.

Grinding the running surface helps to achieve excellent concentricity. All of the materials used can be supplied in antistatic or electroconductive designs, which discharge any electrostatic build-up.

Customer benefits

- ✔ Excellent concentricity and damping properties of the tyre and hub translate into smooth, low-vibration running to stop stored items slipping
- ✔ Optimised PAS-PU TCS material with minimal compression set virtually eliminates flattening after longer stoppages
- ✔ Excellent grip on the track ensures reliable drive transmission
- ✔ Injection-moulded polyamide hub allows for functional integration of connecting and drive elements
- ✔ Reliable operation with heavy loads and at high speeds, including in humid conditions
- ✔ High system availability thanks to excellent tyre bonding
- ✔ Economical solution with short lead times

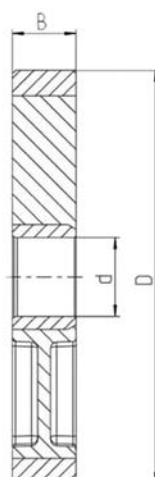

Specifications

- D 100 – 150mm
- d 0 – 50mm
- B 20 – 50mm



Shuttle flaps

Application / Challenges

Shuttle flaps are heavy-duty components in the shuttle systems used in automated warehouses. Their function is to place items in the bays and retrieve them.

When the flaps are raised, a telescopic arm reaches into the bay. The flaps then swing down behind the item and the telescopic arm is retracted, pulling the item with it.

Meeting extremely high load-capacity and durability standards requires extensive expertise in geometry and material design. Most conventional shuttle flaps are milled metal parts which are complicated to produce. It is virtually impossible to manufacture them cost effectively in large volumes.

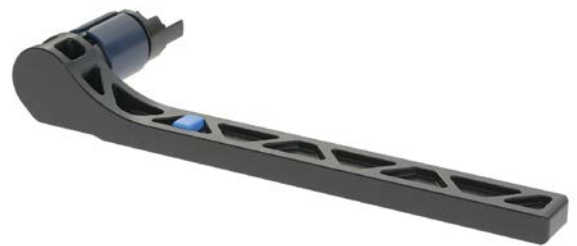

Solution / Material

faigle shuttle flaps are injection moulded and made entirely of plastic. We ensure outstanding load-bearing capacity and durability levels by using an FEM-optimised ribbed construction, as well as PAS-PAA LCF, a carbon-fibre-reinforced material.

The flaps can pass hardness tests involving more than five million load cycles without any breakdowns. What's more, plastic shuttle flaps are about 80% lighter than conventional steel models.

The injection-moulded design allows for the integration of snap and lock functionality, which significantly reduces both the number of components and assembly times. The flaps are fitted with a maintenance-free PAS-LXY plain bearing and two shock absorbers made from soft PAS-PU.

Customer benefits

- ✓ Lightweight design with optimised, high-strength geometry
- ✓ High-performance plastics deliver outstanding durability
- ✓ Extremely cost-effective with short lead times thanks to efficient production using injection moulding
- ✓ Quick and easy assembly due to integration of bearing, drive and damping functions in a single component

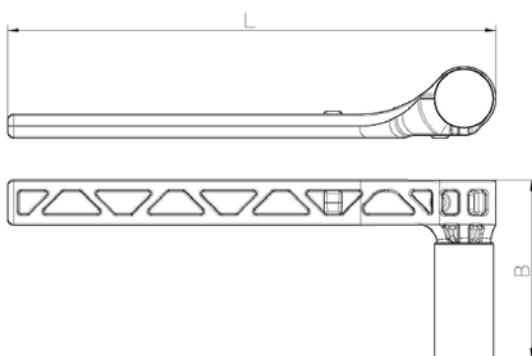

Specifications

L 100 – 300mm
B 15 – 80mm

Customised geometry and detail engineering



Overhead conveyor carriages

Application / Challenges

Overhead conveyors ranging from light to heavy duty are used in industry on various different scales. Besides the track system, the carriages are the central component in these conveyors. faigle offers innovative solutions designed primarily for light to medium-sized carriages.

The wheels used in conveyor systems need to be extremely smooth-running with a burr-free surface, especially if they use gravity to move objects independently along gently sloping tracks. Low-wear, low-noise running over many years – including in environments where dust build-up can be a problem – is the defining feature of a reliable system.

The body of an overhead conveyor carriage is designed with the required centre of gravity in mind. A range of different functions need to be integrated, including the snapping open of the wheels, embedded QR codes or RFID chips, or the option of making modifications depending on the required hook geometry.

Discharge of electrostatic build-ups is also a key requirement for many customers.





Solution / Material

faigle's overhead conveyor carriages feature specially designed smooth-running ball bearings with a contactless cover plate. A range of special high-performance plastics with excellent smooth-running properties, outstanding wear resistance and effective noise insulation qualities are available for the tyre. Enclosed tyres mounted on the outside of the carriage, which protects the ball bearing against dust and other environmental influences, are another option.

The main body is also made from high-performance plastics, and can be fibre-reinforced if required. Snap and slider geometries mean that additional functions can be integrated or shock absorbers fitted.

Special fillers in the material are used to increase the weight, so that the overhead conveyor's centre of gravity can be moved as required.

Antistatic designs are available for all parts on request. faigle delivers fully assembled carriages, including with an integrated RFID chip or laser-etched QR code if required.

Customer benefits

- ✔ Secure operation on gravity sections thanks to very low rolling resistance
- ✔ Ball bearing mostly covered, preventing breakdowns due to dust or other environmental influences
- ✔ No assembly costs – delivered as fully assembled units, with RFID chip or laser engraving on request
- ✔ Function integration and modular construction means fewer components
- ✔ Low-noise operation thanks to dampening materials and precise concentricity
- ✔ Antistatic materials for safe discharge of electrostatic build-up available on request



AGV wheels

Application / Challenges

These wheels are used on automated guided vehicles (AGVs). They bear the weight of the vehicle and the conveyed goods, transmit drive power from the motor to the track, and steer the vehicle.

With only a limited installation space available (in terms of diameter and width), AGV wheels need to withstand very heavy loads and ensure excellent grip on a range of different surfaces. They also have to be extremely wear resistant, including in applications where tight cornering and on-the-spot rotation are essential. Low running resistance and low-friction cornering are important for customers for reasons of energy efficiency, especially in view of the fact that AGVs are battery-operated.

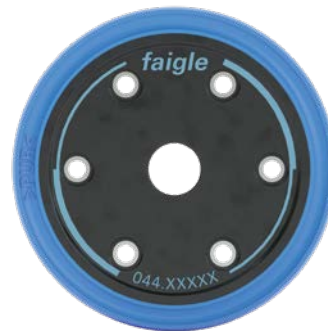



Solution / Material

faigle's AGV wheels usually feature a 2-component design with a polyamide hub and PAS-PU TCS tyre. A very stiff hub ensures a high load-bearing capacity.

The hub geometry is customised in line with the specifications of the drive or the transmission system. If required, faigle can use overmoulding to integrate a metal hub.

The specially developed running surface combines extremely high abrasion resistance with very low running resistance. The wheel can be adjusted to meet the specific requirements of certain surfaces by adapting the tyre material. In addition, a lightly embossed running surface ensures excellent abrasion resistance and friction-free running during sharp cornering.

All of the materials used can be supplied in antistatic or electroconductive designs.

Customer benefits

- ✓ Low wear and running resistance for applications requiring tight cornering and on-the-spot rotation
- ✓ High load-bearing capacity, including for wheels with small diameters
- ✓ Excellent grip on the track ensures reliable drive transmission
- ✓ Injection-moulded polyamide hub allows for functional integration of connecting and drive elements
- ✓ Reliable operation with heavy loads and at high speeds, including in humid conditions
- ✓ High system availability thanks to excellent tire bonding

Specifications

- D 75 – 200mm
- B 20 – 50mm

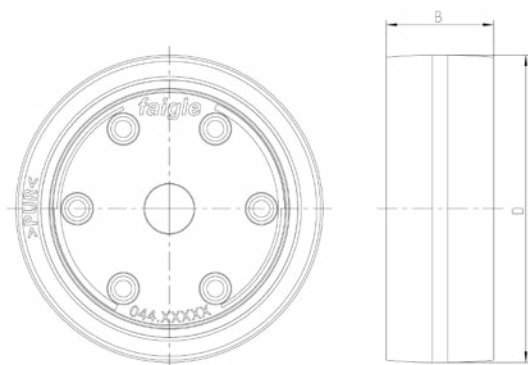

Products and materials – outstanding quality, optimal solutions

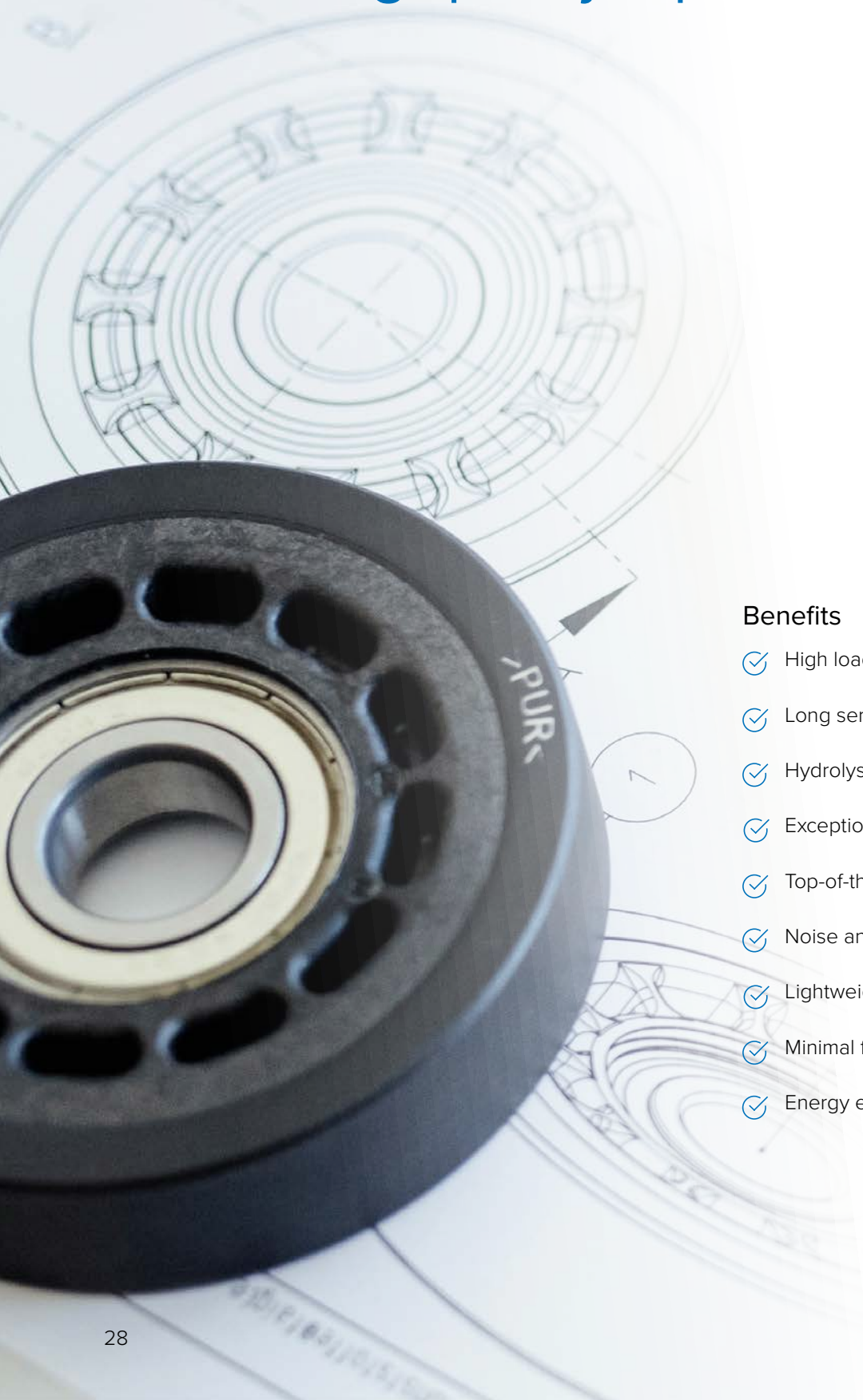

Benefits

- ✓ High load-bearing capacity
- ✓ Long service life
- ✓ Hydrolysis-resistant
- ✓ Exceptional abrasion resistance
- ✓ Top-of-the-range ball bearings
- ✓ Noise and vibration dampening
- ✓ Lightweight design
- ✓ Minimal flattening
- ✓ Energy efficient

Standard materials

PAS-PU H

Thermoplastic polyurethane available in hardnesses ranging from 85 Shore A to 54 Shore D. Extremely wear-resistant, with excellent damping properties and tear resistance.

PAS-80 GF 30

Our standard polyamide-based material for wheel hubs. Fibre-glass-reinforced for optimum strength, impact strength and creep resistance. Secure bonding with the polyurethane tyre.

Ball bearings

Premium ball bearings from approved and audited suppliers in Europe and Asia. RS rubber seals, low-friction RSL rubber seals or steel z-shields available. We can also supply special bearings such as low-friction, deep freeze and stainless steel bearings.



Hydrolysis-resistant material from faigle

Conventional polyurethane can be seriously damaged if it is permeated by water. But faigle has developed a hydrolysis-resistant material designed specifically to overcome this problem.

Extensive testing and over 30 years of practical application have shown that the service life of our PAS-PU H material is more than twice that of conventional materials in humid environments.

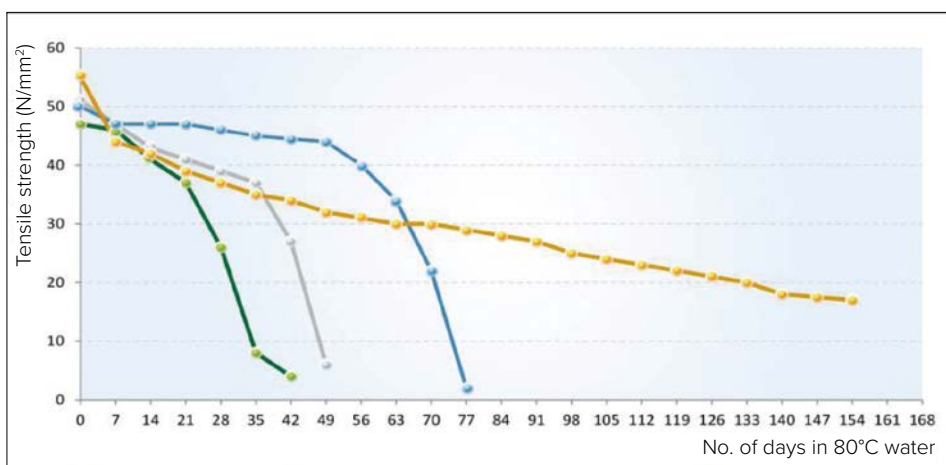

- PU 90A A (non-stabilised)
- PU 90A B (non-stabilised)
- PU 90A TC (hydrolysis-stabilised)
- PU 90A H (hydrolysis-resistant)

Innovative and custom-built – product development services from faigle

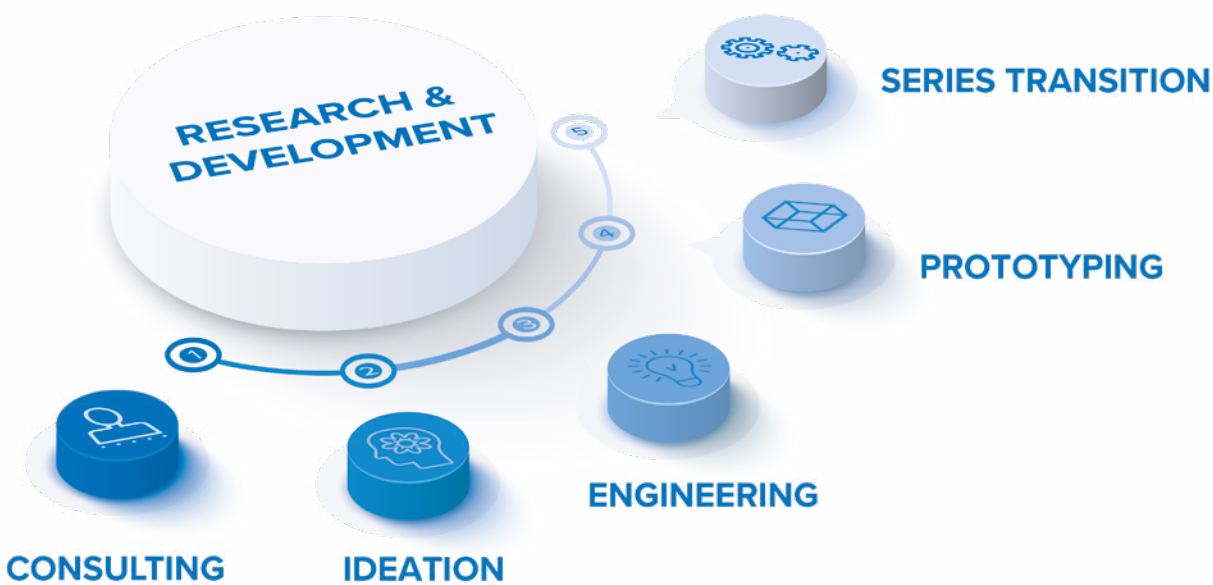

01 Consulting

- ✓ Consulting on applications engineering
- ✓ Selecting plastics materials
- ✓ Presenting practical use cases

02 Ideation

- ✓ Jointly identifying customer needs and operating conditions
- ✓ Developing concepts and product ideas
- ✓ Implementation plus technical and economic feasibility checks

03 Engineering

- ✓ Developing new, custom materials
- ✓ Implementing detail engineering
- ✓ Performing calculations and simulations

04 Prototyping

- ✓ Separate in-house R&D department with team of experts
- ✓ Technology and process refinement
- ✓ Dedicated injection moulding equipment
- ✓ 3D printing

05 Series Transition

- ✓ Product realisation
- ✓ Project and process management
- ✓ Quality management

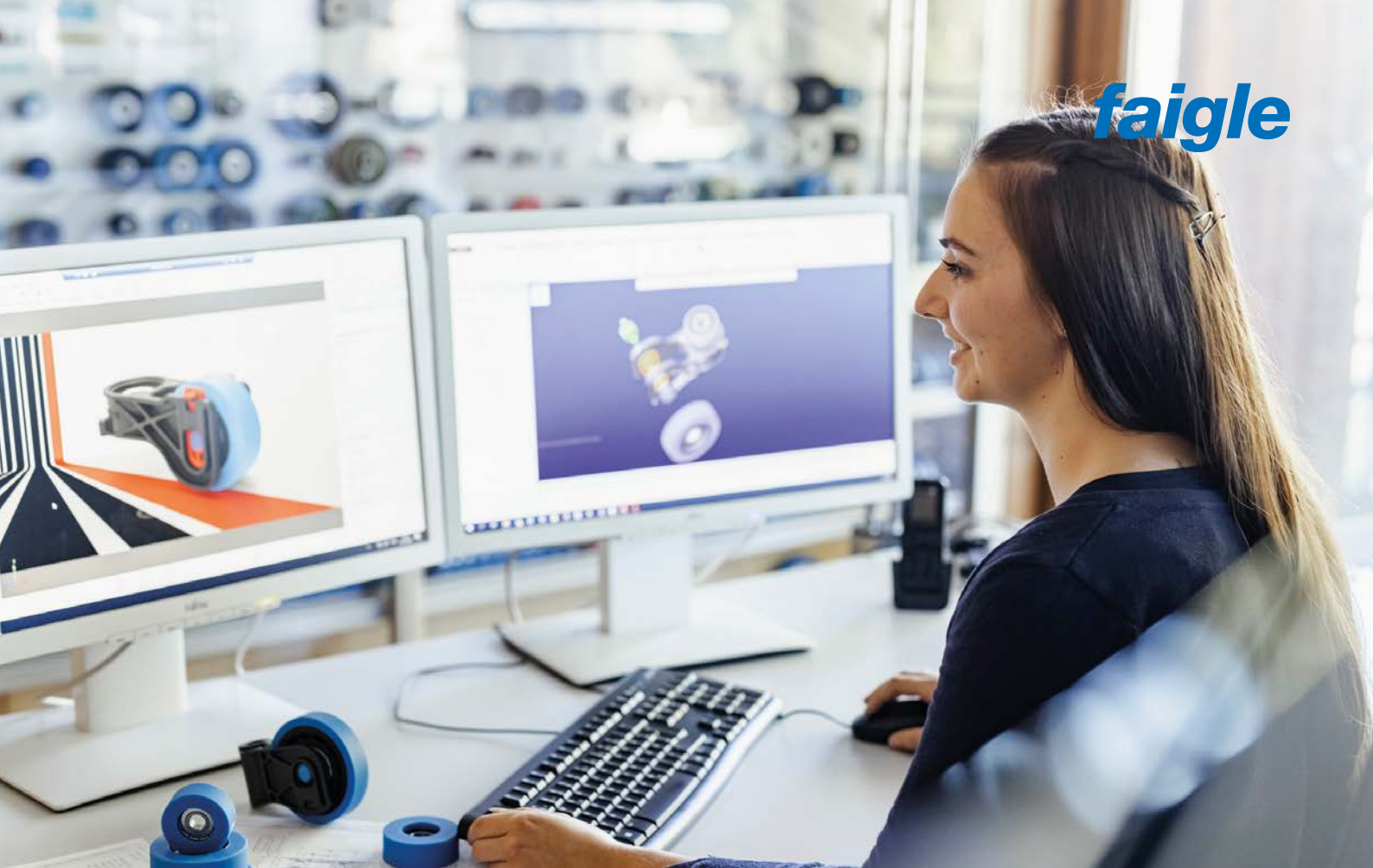

Applications engineering

The experienced engineers at our Development and Technology Centre help our customers to select the most suitable faigle solutions that are then tailored specifically to their needs. Customising existing products to create bespoke faigle solutions is also part of our service portfolio. Our application engineers have access to a knowledge database containing empirical data, test results and expertise collected during faigle's 65 years of development operations.

Custom development

faigle also develops bespoke, customer-specific solutions designed to overcome specialist intralogistics-related challenges. We regularly help customers to deal with issues such as substituting metal parts, energy efficiency, function integration, ease of assembly and approaches aimed at reducing total costs throughout product life cycles.

Modifying plastics materials has enabled us to engineer unrivalled properties for applications across a range of industries, including improved sliding friction, abrasion resistance and the electroconductivity of plastics.

Our engineers use a range of state-of-the-art equipment:

- ✓ Creo 3D CAD software from PTC
- ✓ Finite element method (FEM) for computer-aided material strength calculations
- ✓ Analysis using Moldflow to simulate and optimise injection moulding processes.
- ✓ Rapid prototyping for quick and cost-effective manufacturing of test and other samples

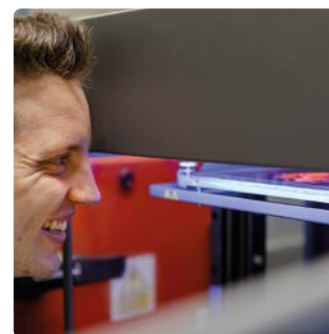



Testing and laboratory equipment

- ✓ Dynamic wheel test benches
- ✓ Rolling resistance test bench
- ✓ Flattening testing
- ✓ Peel testing
- ✓ Ball bearing noise testing
- ✓ Linear tribology test bench
- ✓ Dimensional inspection
- ✓ Digital microscopy
- ✓ Infrared spectroscopy
- ✓ Computer-aided quality assurance (CAQ) system



Find out more about our quality management systems

Quality assurance – outstanding quality from the outset

Quality management has a part to play from the very beginning of the development process, regardless of whether the product concerned is an addition to our current range or a custom solution developed in close consultation with the customer. Defining key quality specifications is the first step towards ensuring that the product meets all of the agreed requirements, and that its suitability can be measured. Our quality management team is involved throughout the development and production process.

faigle uses a variety of testing devices and approaches to ensure that products meet the company's stringent quality standards. Materials and components are tested at the respective production site, for instance in the test centre in Hard and the PAS centre in Suzhou. These facilities allow us to specify all of the key mechanical, thermal, physicochemical, tribological and component-specific properties required for production and the application in question.

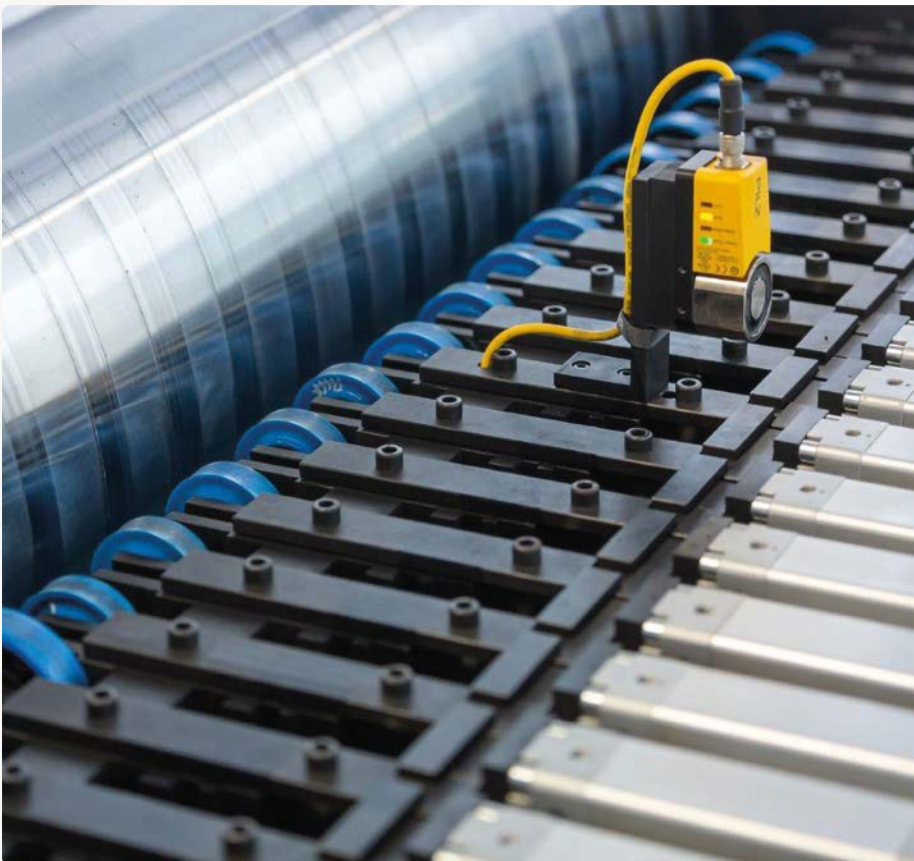

Dynamic wheel test bench



Digital microscopy



Infrared spectroscopy



**SUSTAINABLE
DEVELOPMENT
GOALS**



faigle components – enabling sustainability

When it comes to protecting the environment and the climate, we constantly review the steps we take with a view to achieving continuous improvements. The resource-efficient, lightweight design of our products means that the facilities where they are deployed require less energy to make the wheels accelerate, and friction loss is also reduced. This and other measures ensure that the service life of our products is longer than the industry norm. faigle rollers in escalators and sorting systems have an exceptionally long service life, which contributes to waste reduction and at the same time means less maintenance for our customers. We work to continuously optimise running resistance, enabling our customers to improve their energy efficiency. Meanwhile, our development departments examine ways of using climate-friendly materials and enhancing recycling in order to promote closed-loop waste management.

Our aim is to capitalise on these measures in order to improve our carbon footprint – and that of our customers. All of which will help us to preserve the environment for generations to come.

faigle's long-running commitment to promoting sustainability is reflected in its certification in accordance with the Ökoprofit environmental protection initiative and the ISO 14001 standard.

- ✓ **Resource-efficient lightweight construction**
Less energy required for wheel acceleration
- ✓ **Longer wheel service life**
Contributes to waste reduction
Lower maintenance costs
- ✓ **Improved energy efficiency**
Optimised running resistance
- ✓ **Climate-friendly materials**
Improved recycling thanks to closed loop system
- ✓ **Certifications**
Ökoprofit
ISO 14001

faigle ecoWheel –
the industry’s first
climate-friendly
intralogistics wheel



faigle has always been a pioneer – and now it is leading the way by launching the intralogistics industry's first climate-friendly wheel: the ecoWheel. In order to meet the sophisticated requirements for the product's technical properties while also ensuring sustainable production, the Group has set up partnerships with a number of other plastics manufacturers. The upshot – two extremely promising plastics. PAS-60 GF ECO contains at least 70% recycled material – use of recycled plastics does not mean making sacrifices in terms of material properties. The second material, PAS-PU 90A ECO, is a biobased polyol – 37% of the raw materials used are biomass-based. It has excellent material properties, which in some cases outperform conventional new materials made from customary plastics. Overall, the use of eco-friendly raw materials translates into a 50% reduction in the carbon footprint attributable to production.

Besides these advantages, as a premium-quality faigle product it goes without saying that ecoWheel has other properties which help customers to save energy and protect the environment. In terms of its lightweight design, energy efficiency and service life, the new product is more than a match for intralogistics wheels manufactured using conventional methods.

- ✔ **Biomass-based raw material and use of recycled materials**
 - **PAS-60 GF ECO**
 - 70% recycled material
 - Certified origin – all raw materials produced in Europe
 - Fully equivalent to new material
 - **PAS-PU 90A ECO**
 - Made from biobased polyol
 - 37% biomass-based materials
 - All raw materials from non-GMO/food/animal feed sources
 - Specific material properties outperform new material in some cases
- ✔ **Lightweight design**
- ✔ **Energy-efficient thanks to reduced running resistance**
- ✔ **Outstanding service life**
- ✔ **Compatible with most intralogistics systems**
- ✔ **Recyclable**

Take a look also at our roller catalog
for intralogistics systems





range

044.01970
Roller 2K 90x22 95A-H 6204 2Z
PAS-PU 95A-H blue
PAS-80 GF30
D 90.00
B 22.00
d 20.00
b 14.00
6204 2Z

044.00078
Roller 1C 30x15 95A-TC 626 2Z
PAS-PU 95A-TC blue
D 30.00
B 15.00
d 6.00
b 6.00
626 2Z SFBC

01
26x12 95A-TC 6001 2Z
A-TC black

(b)

Standard wheel range



Article	044.00077
Description	Roller 1C 40x15 95A-TC 626 2Z
Tire material	PAS-PU 95A-TC blue
Hub material	
Dimensions (mm)	D 40.00 B 15.00 d 6.00 b 6.00
Bearing	626 2Z SFBC



Article	044.00076
Description	Roller 1C 40x20 90A-H 6200 2Z
Tire material	PAS-PU 90A-H blue
Hub material	
Dimensions (mm)	D 40.00 B 20.00 d 10.00 b 9.00
Bearing	6200 2Z SFBC



Article	044.00044
Description	Roller 1C 50x20 90A-H 6201 2Z
Tire material	PAS-PU 90A-H blue
Hub material	
Dimensions (mm)	D 50.00 B 20.00 d 12.00 b 10.00
Bearing	6201 2Z SFBC



Article	044.00572
Description	Roller 1C 50x20 90A-H 6201 2Z P
Tire material	PAS-PU 90A-H blue
Hub material	
Dimensions (mm)	D 50.00 B 20.00 d 12.00 b 10.00
Bearing	6201 2Z Prime

Outer diameter (D) | Inner diameter (d) | Width (B) | Ball bearing width (b)



Here you will find the entire standard roller program and other useful information. All products can also be found clearly and described in detail on our website www.faigle.com

faigle intralogistics components – working reliably all over the world



If you have any questions or need further information, we'll be happy to talk to you.

Tel. +43 5574 6811
intralogistics@faigle.com

faigle Kunststoffe GmbH

a faigle Group company
Landstrasse 31
6971 Hard · Austria
T +43 5574 6811
kunststoffe@faigle.com
www.faigle.com

faigle Igoplast AG

a faigle Group company
Werkstrasse 11
9434 Au · Switzerland
T +41 71 747 41 41
igoplast@faigle.com
www.faigle.com

Suzhou faigle Engineering Plastics Co., Ltd.

a faigle Group company
No. 7 Taiqian Road · New District
215129 Suzhou · China
T +86 512 8817 8023
sales.china@faigle.com
www.faigle.com