

SHUTTLE FLAPS



APPLICATION, CHALLENGES

Shuttle flaps are high-stress components in shuttle systems used in automated high-bay warehouses to store and retrieve goods to and from bays. The telescopic arm into the bay with shuttle flaps raised. The flaps down behind the storage item and the telescopic arms moves flip more bad together with the item. The extremely high requirements for mechanical strength and durability demand enormous expertise when it comes to designing the geometry and selecting the materials.

DESIGN, MATERIALS

Conventional shuttle flaps are usually complex milled metal parts. It is hardly possible to produce such parts in high volumes economically. Shuttle flaps from **faigle** are injection moulded parts completely made of plastic. The high requirements for mechanical strength and durability are met by an FEM-optimised ribbed construction made of the carbon fibre reinforced material PAS-PAA-LCF. This material passed a endurance test without failure after over 5 million load cycles. The plastic shuttle flap is about 80% lighter than a conventional steel design. The design possibilities of injection moulding mean that snapping and coupling functions can be integrated in the part and this reduces the number of components. The component comprises a maintenance-free slide bearing made of PAS-LXY and 2 stop dampers made of resilient PAS-PU.

SHUTTLE FLAPS

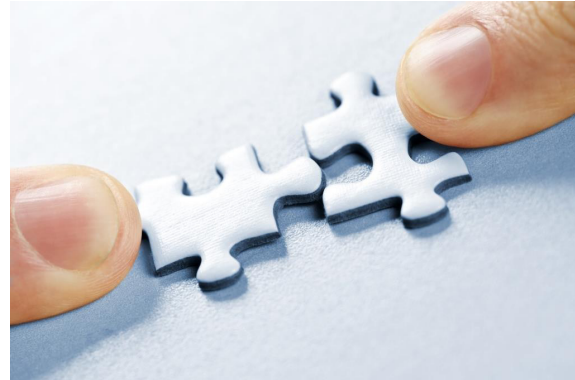
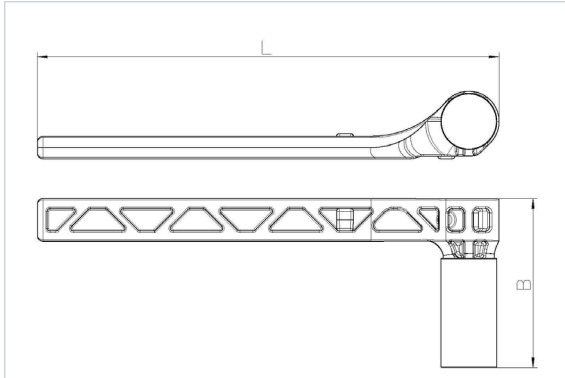

SPECIFICATIONS

- _ L 100 – 300 mm
- _ B 15 – 80 mm

Geometry, detailed construction to customer specifications

CUSTOMER BENEFITS

- _ Lightweight design with strength-optimised geometry
- _ Highest durability
- _ Function integration with integrated bearing, snap-lock and coupling
- _ Excellent price-performance ratio by using efficient injection moulding processes

faigle Kunststoffe GmbH

Landstrasse 31
A-6971 Hard · Austria
T +43 (0) 5574/6811
kunststoffe@faigle.com
www.faigle.com

faigle Igoplast AG

Werkstrasse 11
CH-9434 Au/SG · Switzerland
T +41 (0) 71 747 41 41
igoplast@faigle.com
www.faigle.com/igoplast

Suzhou faigle Engineering Plastics Co., Ltd.

No. 32–369 Tayuan Road Suzhou New District
215129 Suzhou · China
T +86 (0) 512/6536 5886
office.suzhou@faigle.com
www.faigle.com/suzhou